

This content is also available in French. The *Charter of the French language*, its regulations and the **ministerial directive** govern the **consultation of English-language content**.

Guide for Parents

MINISTERIAL EXAMINATION

Applied Science and Technology
Secondary IV

557-410

Updated December 2025

Coordination and content

Direction de l'évaluation des apprentissages
Direction générale de la formation générale des jeunes et des adultes
Secteur de la pédagogie et des services à l'enseignement

Title of original document

Guide à l'intention des parents
Épreuve ministérielle
Applications technologiques et scientifiques
4^e année du secondaire

English version

Services linguistiques en anglais
Direction du soutien au réseau éducatif anglophone
Ministère de l'Éducation

General information

Ministère de l'Éducation
1035, rue De La Chevrotière, 27^e étage
Québec (Québec) G1R 5A5
Telephone: 418-643-7095
Toll-free: 1-866-747-6626

© Gouvernement du Québec
Ministère de l'Éducation

ISSN 2818-9493 (PDF)
(French version: ISSN 2818-9485)

TABLE OF CONTENTS

INTRODUCTION.....	1
SECTION 1 MINISTERIAL EXAMINATIONS.....	1
NATURE AND OBJECTIVES OF THE EXAMINATIONS.....	1
CONDITIONS FOR ADMINISTERING THE EXAMINATIONS.....	1
SECTION 2 OVERVIEW OF THE EXAMINATION FOR APPLIED SCIENCE AND TECHNOLOGY	2
EVALUATION OF COMPETENCIES.....	2
SUMMARY OF THE EXAMINATION	2
STRUCTURE AND CONTENT OF THE EXAMINATION	3
AUTHORIZED AND UNAUTHORIZED MATERIALS.....	4
SECTION 3 STEPS IN THE EXAMINATION FOR APPLIED SCIENCE AND TECHNOLOGY	5
WRITING THE EXAMINATION	5
MARKING.....	6
SECTION 4 EXCERPTS FROM MINISTERIAL EXAMINATIONS FOR APPLIED SCIENCE AND TECHNOLOGY	7
EXAMPLES OF QUESTIONS IN PART A.....	7
EXAMPLES OF QUESTIONS IN PART B.....	9
EXAMPLE OF A DIAGRAM OF THE TECHNICAL OBJECT IN PART C	12
EXAMPLES OF QUESTIONS IN PART C.....	13
EXCERPT FROM THE REFERENCE DOCUMENT.....	15
APPENDIX COMPULSORY CONCEPTS ON WHICH STUDENTS MAY BE TESTED IN THE APPLIED SCIENCE AND TECHNOLOGY MINISTERIAL EXAMINATIONS (557-410).....	16

INTRODUCTION

This guide is designed to inform parents about the Secondary IV ministerial examination for Applied Science and Technology. It presents the structure of the exam and the administration procedures, as well as sample documents from past exams.

The [Information Document](#), which provides complementary information, is also a recommended resource.

The [Support Document](#) provides clarifications regarding the compulsory concepts on which candidates may be tested in the Secondary IV ministerial examinations in Science and Technology and Applied Science and Technology.

SECTION 1 MINISTERIAL EXAMINATIONS

NATURE AND OBJECTIVES OF THE EXAMINATIONS

The Secondary IV and V ministerial examinations are set by the Minister of Education for the certification of studies and for awarding the Secondary School Diploma. Every year, the Ministère organizes three exam sessions for these examinations: one in December/January, one in May/June and one in August.

Each ministerial examination is designed to evaluate the learning set out in the [Québec Education Program](#) and is based on the [Framework for the Evaluation of Learning](#) and the [Progression of Learning](#).

As everyone enrolled in any given exam session must write the same examination, the dates and times indicated in the [official schedule](#) must be respected. Only the Minister may authorize changes to the set schedule.

CONDITIONS FOR ADMINISTERING THE EXAMINATIONS

Educational institutions are the main entities responsible for making the necessary arrangements for the exams to take place (e.g. providing examination rooms), regardless of the education model (teaching provided at school or homeschooling).

To ensure equity and justice, the exam conditions must be the same for all candidates in Québec who write the exams. For this reason, the individuals designated to administer the examinations are given precise instructions to follow.

During an examination, it is forbidden for anyone to help the candidates in any way whatsoever by, for example, clarifying the task, providing additional information, explaining or translating words or expressions, or reformulating instructions. Examinations where a staff member has overstepped the boundaries of their role may be declared invalid by the Ministère.

Measures that adapt the conditions for administering ministerial examinations may be taken to enable candidates with specific needs to demonstrate their learning. In order to request special measures, please communicate with the educational institution responsible for administering the examination at the beginning of the school year or, in the context of homeschooling, when setting up the learning project. The educational institution will analyze the candidate's needs and determine which adaptive measures will be permitted, if any.

SECTION 2 OVERVIEW OF THE EXAMINATION FOR APPLIED SCIENCE AND TECHNOLOGY

EVALUATION OF COMPETENCIES

The Secondary IV Applied Science and Technology examination, which focuses on the theory component of the program, is designed to evaluate the following competencies:

- Competency 2, *Makes the most of [their] knowledge of science and technology*
- Competency 3, *Communicates in the languages used in science and technology*

SUMMARY OF THE EXAMINATION

The Applied Science and Technology examination takes place in an exam room at a specific time, as set out in the [official schedule](#), and lasts 3 hours.

In the examination, candidates must analyze situations and a technical object, working alone to solve various problems using their knowledge of the compulsory concepts in the program.

The examination consists of 25 questions worth 4 marks each, and is divided into 3 parts:

- Part A: 15 multiple-choice questions
- Part B: 4 constructed-response questions
- Part C: 6 constructed-response questions pertaining to a technical object

STRUCTURE AND CONTENT OF THE EXAMINATION

The compulsory concepts in the Applied Science and Technology program are divided into major areas. The questions in the ministerial examination may cover these concepts (see list in appendix), with the notable exception of those related to the Living World. The table below shows the number of questions related to each major area in each part of the examination.

DISTRIBUTION OF QUESTIONS IN EACH MAJOR AREA OF THE APPLIED SCIENCE AND TECHNOLOGY PROGRAM AND RELATED WEIGHTING

Part	Number of Questions per Part	The Living World	The Earth and Space	The Material World	The Technological World	Weighting
A	15	---	1	9	5	60%
B	4	---	1	2	1	16%
C	6	---	---	---	6	24%
Total	25	---	2 (8%)	11 (44%)	12 (48%)	100%

The examination tests the candidate's knowledge of specific scientific and technological concepts, as well as their ability to correctly apply this knowledge and provide appropriate explanations or solutions for scientific and technological problems. For the purposes of evaluating candidates in this regard, exam questions may involve one of the following tasks:

- identification or understanding of a concept
- identification or formulation of examples pertaining to a concept
- simple application of a formula or an idea related to a concept
- understanding of a combination of concepts
- application of a complex procedure
- explanation or justification of one or more concepts that may require analysis

AUTHORIZED AND UNAUTHORIZED MATERIALS

Authorized materials

Only the following materials may be brought and used during the examination:

- ruler
- calculator (that complies with the rules described below)

For the June examination, candidates must bring an **HB pencil**.

Rules for using calculators

Calculators with or without a graphic display may be used during the ministerial examination for Secondary IV Applied Science and Technology.

Calculators with a computer algebra system (CAS) are permitted only if this system is disabled for the entire examination.

In the interest of fairness regarding applications on a computer, tablet or calculator, certain functions must be disabled or monitored. The use of these applications must be planned in conjunction with the educational institution responsible for administering the examination, either at the start of the school year or, in the case of homeschooling, when the learning project is implemented.

The data and programs stored in the calculator's memory must be deleted before the examination begins. Candidates must therefore have been given the opportunity beforehand to learn how to reset their calculator's memory. In addition, it is forbidden to store programs and data libraries in the calculator's memory during the examination.

User guides, memory expansion features or any other calculator accessories or peripherals are not allowed during the examination. Communication between calculators is also not permitted during the examination.

If, during the examination, a candidate is caught in possession of a calculator whose memory contains data or programs, this will be considered a form of cheating, and the examination may be declared invalid by the Ministère.

Candidates may not lend their calculator to other candidates or borrow one from them.

Unauthorized materials

No other materials are permitted.

Candidates may not bring a memory-aid sheet to the examination, and they are strictly forbidden to have **in their possession** any personal mobile device (smartphone, wireless headphones or earbuds, smartwatch, etc.).

SECTION 3 STEPS IN THE EXAMINATION FOR APPLIED SCIENCE AND TECHNOLOGY

WRITING THE EXAMINATION

Upon arrival in the examination room, each candidate receives the following documents:

- a Student Booklet, which contains the 15 multiple-choice questions in Part A and the 10 constructed-response questions in Parts B and C of the examination
- a Reference Document, which contains the sheet of formulas and quantities and the diagrams of the technical object
- an answer sheet for the multiple-choice questions (for the January and August examinations)
- a scannable answer sheet for the multiple-choice questions (for the June examination)

Working alone, candidates have 3 consecutive hours to answer all the questions in the examination. The examination consists of 25 questions worth 4 marks each. It is divided into three parts. Candidates can start with any part they like.

Part A

Part A consists of 15 multiple-choice questions.

For the June exam, candidates indicate their answers on a sheet that will be marked by a scanner, which can only read answers indicated with an **HB pencil**.

For each question, candidates must fill in the circle that corresponds to their answer, as shown in the example below.

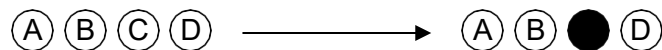

For the January and August examinations, candidates indicate their answers on an answer sheet.

For each question, candidates must fill in the box that corresponds to their answer, as shown in the example below.

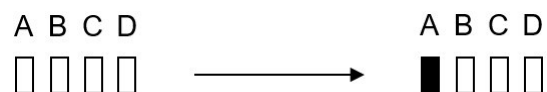

Examples of questions in Part A are provided on pages 7 and 8.

Part B

Part B consists of 4 constructed-response questions.

In this part of the examination, candidates may be required to solve a problem, select the correct answer from among several choices or provide an explanation.

In the Student Booklet, they show all the work involved in solving a problem, check off the correct answer, provide an explanation or a justification, or provide a representation, for example by drawing.

Examples of questions in Part B are provided on pages 9 to 11.

Part C

Part C consists of 6 questions on the technological analysis of a technical object.

In order to be able to answer these 6 questions, candidates must analyze how the technical object works. To do this, they must examine the diagrams found in the Reference Document and view a video that shows the object in motion. This video plays continuously in the exam room during the examination.

While viewing the video of the technical object, candidates are forbidden to communicate with one another or to ask a school staff member questions about the technical object.

An example of a diagram and examples of questions in Part C are provided on pages 12 to 14.

Throughout the examination, candidates can, if necessary, consult the sheet of formulas and quantities found in the Reference Document. The sheet is provided on page 15.

If after 3 hours a candidate has not finished writing the examination, 15 more minutes may be allotted, as specified in the [Administrative Guide for the Certification of Studies and Management of Ministerial Examinations](#).

At the end of the examination, candidates must hand in to the examiner all the exam documents before leaving the examination room.

No candidates may leave the examination room before at least half the time allotted for the exam has elapsed. Any candidate who has a good reason to leave the examination room must be accompanied by an authorized person designated by the educational institution.

MARKING

The corrector will mark the examination using the answer key provided by the Ministère.

SECTION 4 EXCERPTS FROM MINISTERIAL EXAMINATIONS FOR APPLIED SCIENCE AND TECHNOLOGY

EXAMPLES OF QUESTIONS IN PART A

The Earth and Space

Which of the following choices (A, B, C or D) correctly indicates a form of energy with its corresponding characteristics?

	Form of energy	Characteristics
A)	Nuclear energy	<ul style="list-style-type: none">• Produces radioactive waste• Produces high levels of greenhouse gases
B)	Wind energy	<ul style="list-style-type: none">• Is a non-renewable resource• Produces very low levels of greenhouse gases
C)	Hydroelectric energy	<ul style="list-style-type: none">• Requires the flooding of certain areas• Produces very low levels of greenhouse gases
D)	Fossil energy	<ul style="list-style-type: none">• Is a renewable resource• Produces high levels of greenhouse gases

The Material World

The rating plate for an electric motor is given below.

120 V	3.5 A
60 Hz	LR Model

If the motor runs 8 hours per day for 5 days, how much energy will it consume?

- A) 16.8 kW•h
- B) 140 kW•h
- C) 2 400 kW•h
- D) 3 360 kW•h

The Technological World

Special shoes are needed to go up a climbing wall.



Which word below completes the following sentence correctly?

Rubber soles give these shoes greater . . .

- A) . . . adhesion.
- B) . . . hardness.
- C) . . . malleability.
- D) . . . stiffness.

EXAMPLES OF QUESTIONS IN PART B

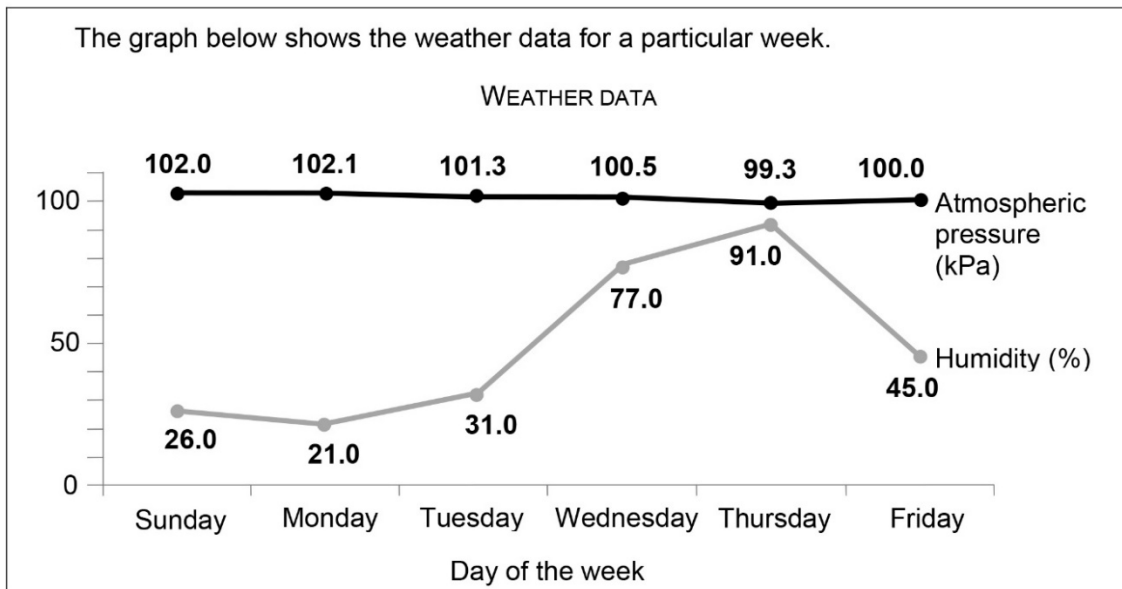

The Earth and Space



a) Using the data from the graph above, indicate the type of weather system on **Sunday** and **Monday**. Check off your answer in the table below.

Type of weather system	<input type="checkbox"/> Anticyclone	<input type="checkbox"/> Cyclone
------------------------	--------------------------------------	----------------------------------

b) Using the data from the graph above, indicate the direction in which the air moved in the weather system on **Wednesday** and **Thursday**, as well as the characteristic and weather conditions related to the movement of the air. Check off your answers in the table below.

Direction in which the air moved	<input type="checkbox"/> 	<input type="checkbox"/> 
Characteristic	<input type="checkbox"/> Warm air	<input type="checkbox"/> Cold air
Weather conditions	<input type="checkbox"/> Cloudy skies	<input type="checkbox"/> Clear skies

The Material World

It took an airplane 5 hours to fly 4 100 km over the ocean. On the way, it flew over an island that is 45 km long.

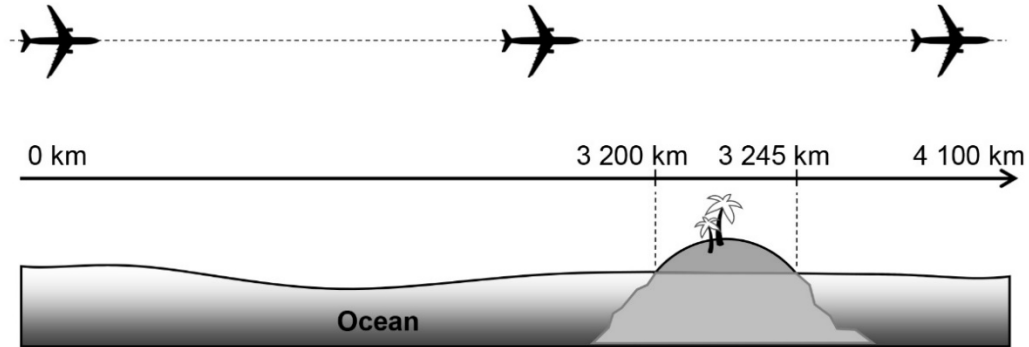

- a) What was the average speed of the airplane for the entire flight?
Show all your work.

The average speed of the airplane was

- b) How much time did it take the airplane to fly over the island, if it flew over it at a constant speed of 900 km/h?
Show all your work.

It took the airplane to fly over the island.

The Technological World

Annie built a miniature merry-go-round activated by a crank. She would like this merry-go-round to rotate twice as slowly as the gear connected to the crank.

- a) In the diagram below, check off the correct box to indicate which gear is the driver component and which gear is the driven component.

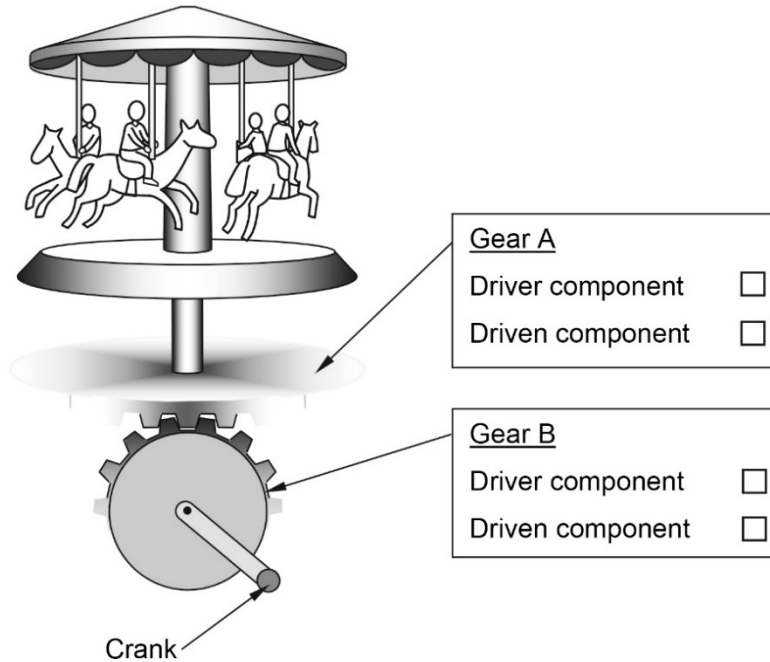

- b) Give an example of the number of teeth each gear could have in order for the driven component to rotate **twice as slowly** as the driver component.

Driver component:

Driven component:

- c) Explain why this mechanism is reversible.

This mechanism is reversible because . . .

.....
.....

EXAMPLE OF A DIAGRAM OF THE TECHNICAL OBJECT IN PART C

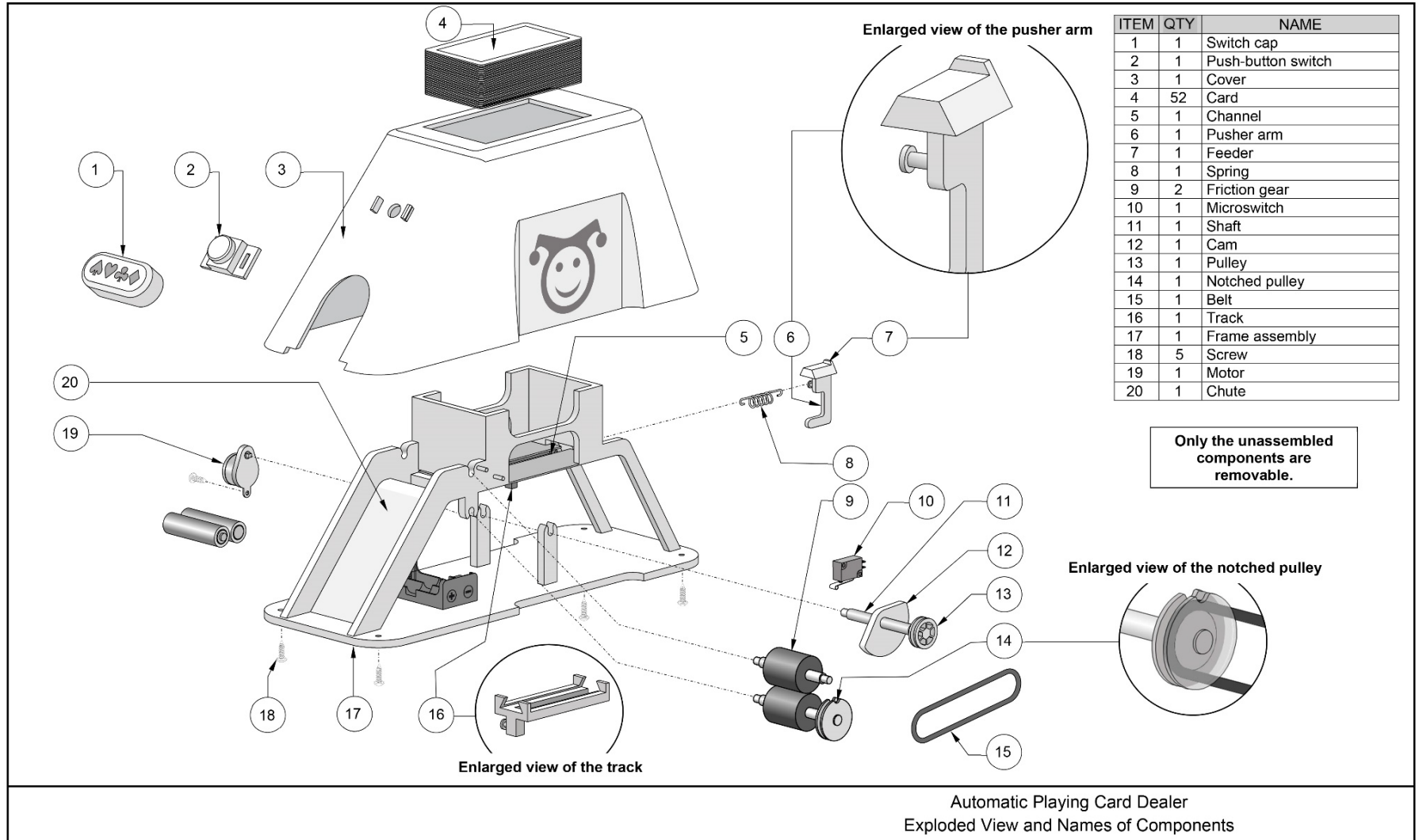

EXAMPLES OF QUESTIONS IN PART C

The following sample questions are related to the technical object presented on the previous page.

The Technological World

Using correct technological language, explain how the automatic playing card dealer operates by describing how the components in each group listed work together.

Examples of answers are given below.

Switch cap, push-button switch **and** motor

.....
.....
.....

Motor, shaft, cam **and** pulley

The motor gives the shaft rotational motion that is transmitted to the cam and the pulley because they are interdependent.

Cam **and** pusher arm

.....
.....
.....

Feeder, pusher arm **and** spring

The feeder and the pusher arm move a card forward. The spring ensures the return movement of the pusher arm.

Pulley, belt **and** notched pulley

.....
.....
.....

Notched pulley, microswitch **and** motor

.....
.....
.....

Friction gears, card **and** chute

The friction gears carry the card along and guide it into the chute. The card is dealt.

The Technological World

Name the four characteristics of the link identified below, using words from the following vocabulary list.

Suggested Vocabulary

Complete – Direct – Flexible – Indirect
Non-removable – Partial – Removable – Rigid

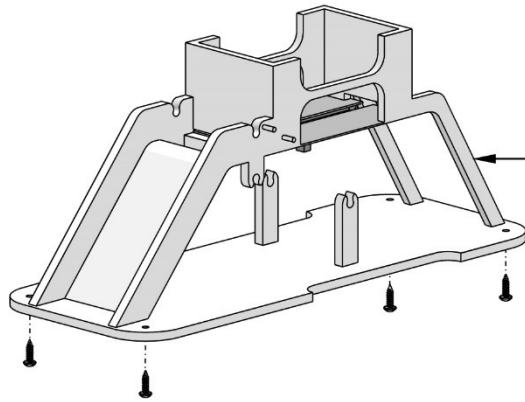
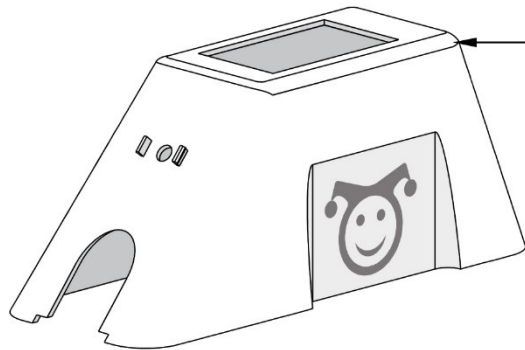

Characteristics of the link between the
cover and the **frame assembly**

FORMULAS AND QUANTITIES

Applied Science and Technology

FORMULAS	
$V = RI$ <p style="margin-left: 20px;">V : potential difference R : resistance I : electric current intensity</p> $P = VI$ <p style="margin-left: 20px;">P : electrical power V : potential difference I : electric current intensity</p> $E = P\Delta t$ <p style="margin-left: 20px;">E : energy consumed P : electrical power Δt : time difference</p>	$F_g = mg$ <p style="margin-left: 20px;">F_g : gravitational force m : mass g : intensity of the gravitational field</p> $v = \frac{d}{\Delta t}$ <p style="margin-left: 20px;">v : speed d : distance Δt : time difference</p>
$\text{Energy efficiency (\%)} = \frac{\text{Amount of useful energy}}{\text{Amount of energy consumed}} \times 100$	

QUANTITIES		
NAME	SYMBOL	VALUE
Intensity of the gravitational field on Earth	g	9.8 N/kg
Kilowatt hour	kW•h	1 kW•h = 3 600 000 J

APPENDIX COMPULSORY CONCEPTS ON WHICH STUDENTS MAY BE TESTED IN THE APPLIED SCIENCE AND TECHNOLOGY MINISTERIAL EXAMINATIONS (557-410)

The scope of each concept is defined in the Progression of Learning.		
The following are also evaluated: Techniques related to diagram drawing and graphic representation (multiview orthogonal projection, isometric representation, perspective drawing), use of scales.		
The Earth and Space	The Material World	The Technological World
<p>Lithosphere – Energy resources</p> <p>Hydrosphere – Catchment area – Energy resources</p> <p>Atmosphere – Cyclone and anticyclone – Energy resources</p> <p>Space – Earth-Moon system (gravitational effect)</p>	<p>Chemical changes – Combustion – Oxidation</p> <p>Electricity – Electrical charge – Static electricity – Ohm’s law – Electrical circuits – Relationship between power and electrical energy</p> <p>Electromagnetism – Forces of attraction and repulsion – Magnetic field of a live wire – Magnetic field of a solenoid – Electromagnetic induction</p> <p>Transformation of energy – Law of conservation of energy – Energy efficiency</p> <p>Fluids – Archimedes’ principle – Pascal’s principle – Bernoulli’s principle</p> <p>Forces and motion – Force – Types of forces – Equilibrium of two forces – Relationship between constant speed, distance and time – Mass and weight</p>	<p>Graphical language – Multiview orthogonal projection (general drawing) – Functional dimensioning – Developments (prism, cylinder, pyramid, cone) – Standards and representations (diagrams, symbols)</p> <p>Mechanical engineering – Adhesion and friction of parts – Linking of mechanical parts (degree of freedom of a part) – Guiding controls – Construction and characteristics of motion transmission systems (friction gears, pulleys and belt, gear assembly, sprocket wheels and chain, wheel and worm gear) – Speed changes – Construction and characteristics of motion transformation systems (screw gear system, connecting rods, cranks, slides, cams, eccentrics and rotating slider crank mechanisms, rack-and-pinion drive)</p> <p>Electrical engineering – Power supply – Conduction, insulation and protection (resistance and coding) – Control [types: unipolar (single-pole), unidirectional (single-throw), bidirectional (double-throw)] – Transformation of energy (electricity, light, heat, vibration, magnetism) – Other functions [capacitor (condenser), diode, relay]</p> <p>Materials – Constraints – Characteristics of mechanical properties – Types and properties – Plastics (thermoplastics, thermosetting plastics) – Ceramics – Modification of properties (degradation, protection)</p> <p>Manufacturing – Manufacturing (characteristics of drilling, tapping, threading and bending)</p>

